

TracXP™ TXP-WABX

Wireless Alarm Bar

Instruction Manual



IMPORTANT: Read and understand contents of this manual prior to operation. Keep these user instructions for reference.

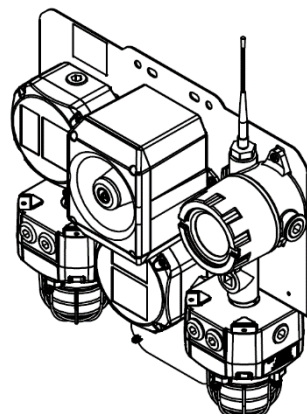
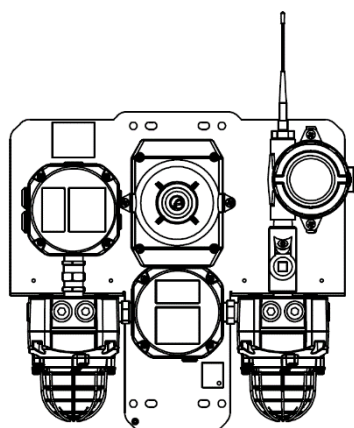

1) Warnings



Warning – High voltage may be present, risk of electric shock. DO NOT open when energised, disconnect power before opening.



Warning – Hot surfaces. External surfaces and internal components may be hot after operation, take care when handling the equipment.

Please see individual product instruction manual. See Table 1 for Instruction Manual Document Number.

2) Rating & Marking Information

All individual unit ratings must be suitable for the installation.

Please see individual product instruction manual. See Table 1 for Instruction Manual Document Number.

3) Special Conditions of Use

Please see individual product instruction manual. See Table 1 for Instruction Manual Document Number.

Component Part # Reference	Component Description	Document Number
TXP-WAR	TXP-WAR Wireless Alarm Relay	34-2900-0208-0
D2xB1X10	10 Joule Xenon Strobe Beacon	D211-00-201-IS
D2xS1	Alarm Horn Sounder	D189-00-001-IS
D2xJ1	Junction Box	D211-00-501-IS

Table 1: Product Instruction Manual Reference

4) Location and Mounting

The location of the Alarm Bar should be made with due regard to the area over which the warning signal must be visible/audible. It should only be fixed to poles that can bear the weight of the unit.

The Alarm Bar should be secured to a pole using supplied TXP-WABX Pole Mounting Kit (Pole size up to 4" NPS).

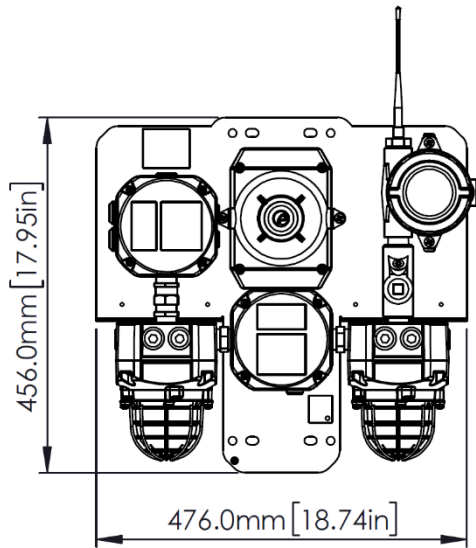

Fig. 1a: Dimensions

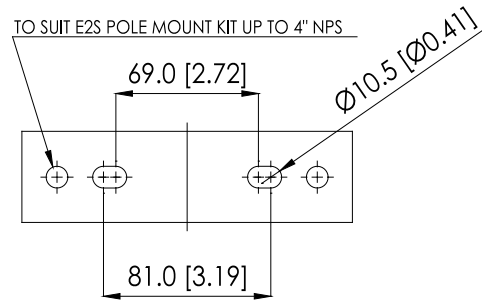

Fig. 1b: Pole Mount Positions

To mount the unit to poles up to size NPS 4", the pole mount kit should be used (Fig. 1b, 1c). The unit should be mounted using all supplied clamps as shown.

See document D214-00-010-IS for pole mount assembly.

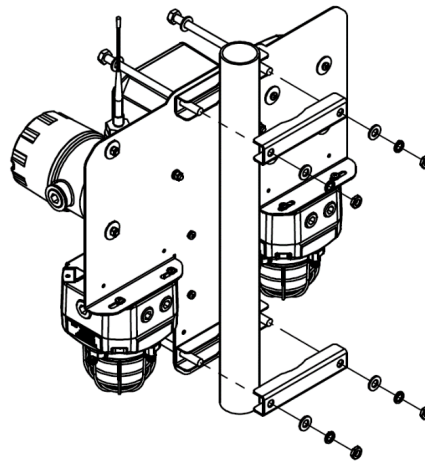

Fig. 1c: TXP-WABX Pole Mount Kit Assembly

5) Access to the Enclosure



Warning – High voltage may be present, risk of electric shock. DO NOT open when energised, disconnect power before opening.



Warning – Hot surfaces. External surfaces and internal components may be hot after operation, take care when handling the equipment.

In order to connect the electrical supply cables to the junction box it is necessary to remove the cover to gain access to the chamber. To access the chamber, loosen the four M4 posi pan head screws and remove the cover. (See figure 2).

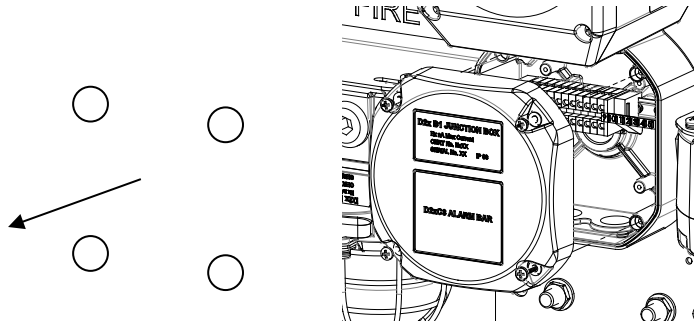

Fig. 2: Accessing the Junction Box

To replace cover, check that the 'O' ring seal is in place. Carefully push the cover in place. Insert and tighten down M4 screws and fibre washers.

6) Power Supply Selection

The Alarm Bar accepts power from a supply providing 115 VAC 50/60Hz. This is converted to 24 VDC via the onboard transformer, which provides DC power to the alarm horn, beacons, and wireless relay.

Please see individual product instruction manual for component Voltage Range, Current and Max Current values.

7) Selection of Cable, Cable Glands, Blanking Elements & Adapters

Please see individual product instruction manual.

The Alarm Bar is supplied with the following cable entries:

- 2 x 1/2" NPT

8) Earthing

The Alarm Bar is provided with an M4 earth post on the plate. External earthing connections should be made to the M4 earthing post (fig. 3) using a ring crimp terminal to secure the earth conductor to the earth stud.

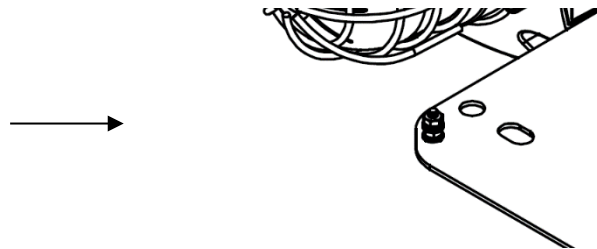

Fig. 3: Plate Earth Screw Location

9) Cable Connections

Electrical connections are to be made into the terminals located in the junction box enclosure. See section 5 of this manual for access to the enclosure. Wires with cross sectional area of 0.5mm² to 2.5mm² may be connected to the terminals. Wires should be stripped to 8mm.

Wires may also be fitted using ferrules. Connections should be tightened with torque 0.56 Nm / 5 Lb-in. When connecting wires to the terminals great care should be taken to dress the wires so that when the cover is inserted into the chamber the wires do not exert excess pressure on the terminal blocks. This is particularly important when using cables with large cross-sectional areas such as 2.5mm².

10) Wiring

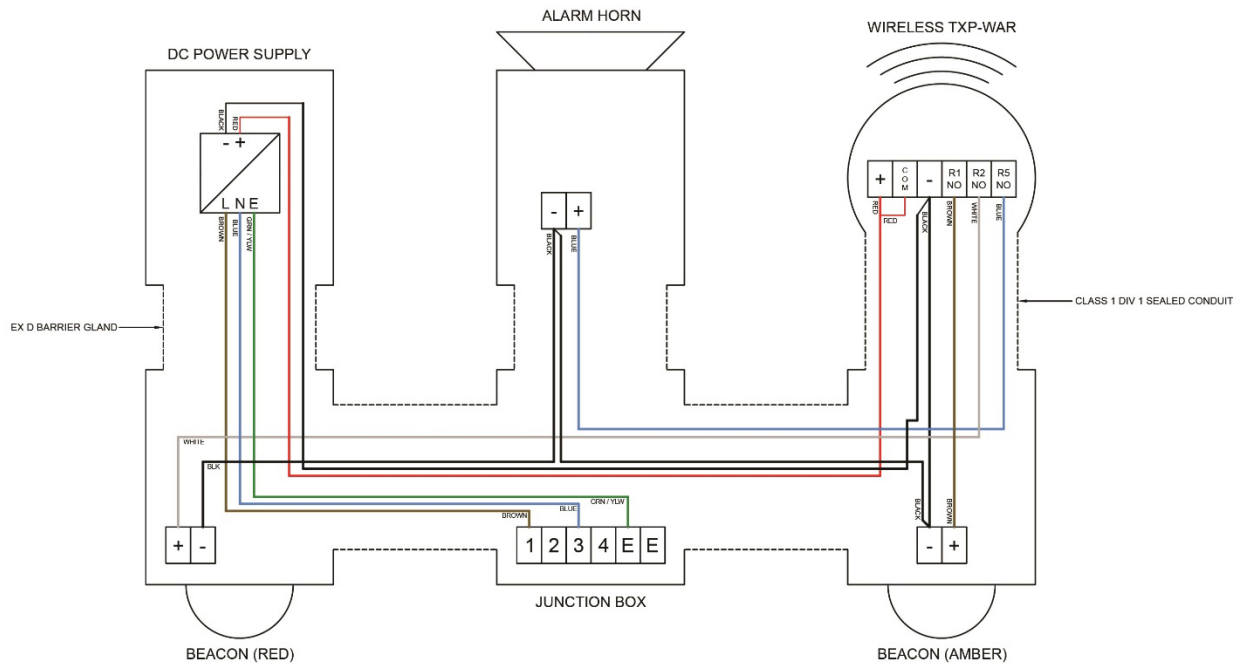

11) Interchangeable & Spare Parts

The Beacon lens cover is interchangeable, contact Macurco for a replacement lens cover available in various colors.

To change the lens cover, unscrew the 4-off M5 posi pan head screws, spring and flat washers using a screwdriver. Remove the wire guard and replace the old lens cover with the new lens cover.

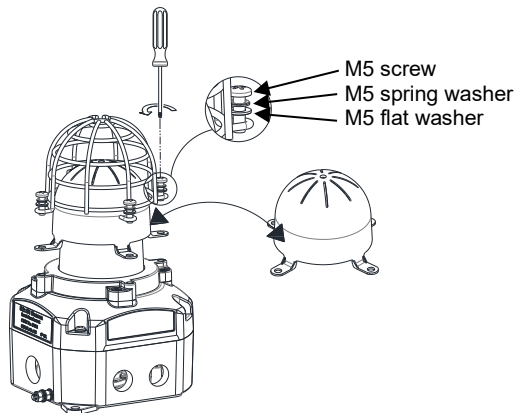

Fig. 4 Replacement of beacon lens cover

12) Maintenance, Overhaul and Repair

Please see individual product instruction manual. See Table 1 for Instruction Manual Document Number.

Macurco Gas Detection Product limited warranty

Macurco warrants the TXP-WABX will be free from defective materials and workmanship for a period of two (2) years from the date of manufacture, provided it is maintained and used in accordance with Macurco instructions and/or recommendations. If any component becomes defective during the warranty period, it will be replaced or repaired free of charge, if the unit is returned in accordance with the instructions below. This warranty does not apply to units that have been altered or had repair attempted, or that have been subjected to abuse, accidental or otherwise. The above warranty is in lieu of all other express warranties, obligations or liabilities. THE IMPLIED WARRANTIES OF MERCHANTABILITY AND FITNESS FOR PARTICULAR PURPOSE ARE LIMITED TO A PERIOD OF TWO (2) YEARS FROM THE PURCHASE DATE. Macurco shall not be liable for any incidental or consequential damages for breach of this or any other warranty, express or implied, arising out of or related to the use of said gas detector. The manufacturer or its agent's liability shall be limited to replacement or repair as set forth above. Buyer's sole and exclusive remedies are the return of the goods and repayment of the price, or repair and replacement of non-conforming goods or parts.

Macurco Gas Detection

1504 West 51st Street
Sioux Falls, SD 57105
United States of America

Technical Support Contact Information

Phone: 1-844-325-3050

Fax: 1-605-951-9616

Email: support@tracxp.com

Website: www.tracxp.com/support/

General Contact Information

Phone: 1-877-367-7891

Fax: 1-605-951-9616

Email: info@tracxp.com

Website: www.tracxp.com

Rev - 1.0

Issue Date: 12-8-2022

Document No: 34-2900-8444-0

© Macurco Inc. 2022. All rights reserved.

